

Surface Track

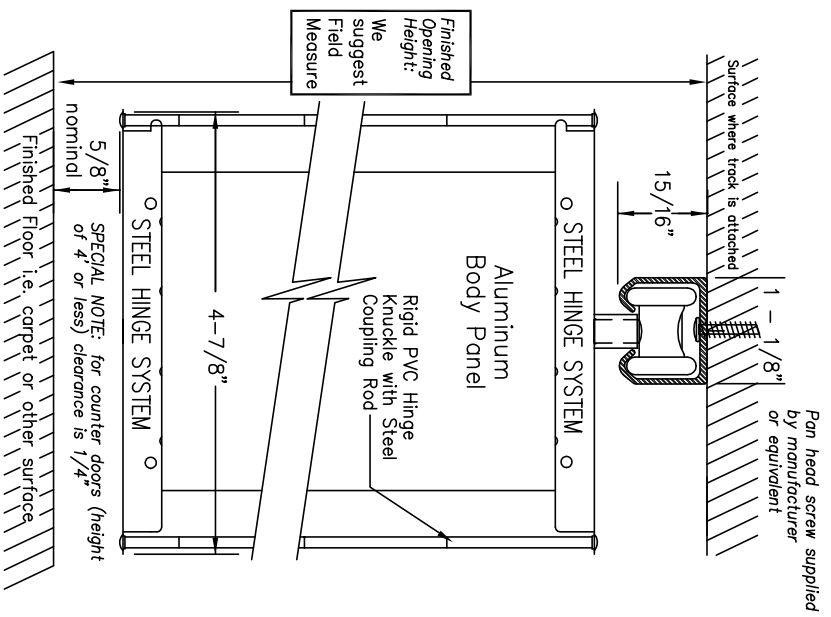

Recessed Track

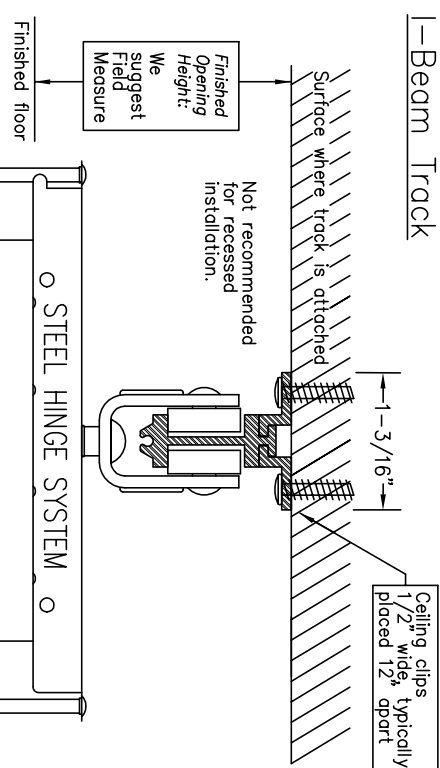
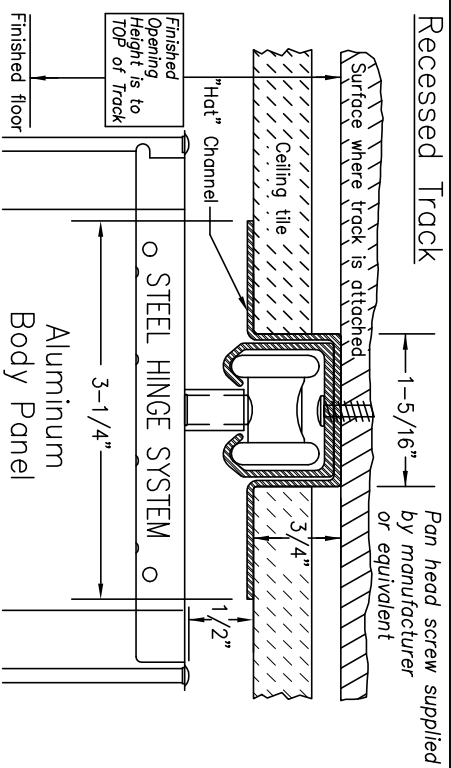

Door Types

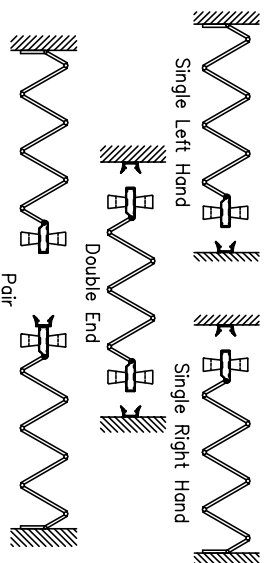

Lead Post

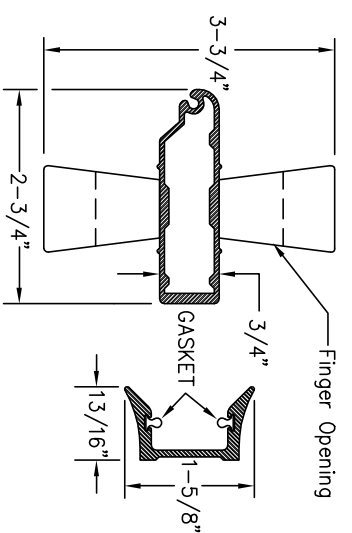

Sliding Jamb Option

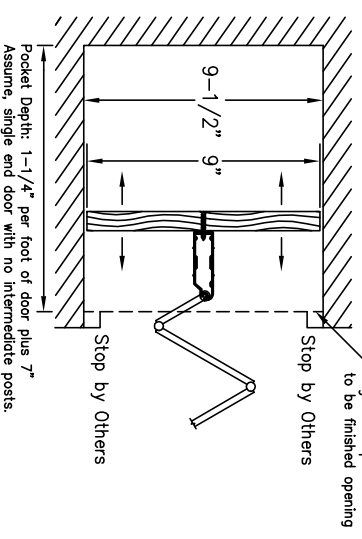

Mounting Panel

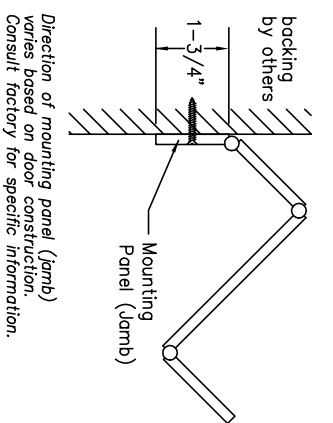

Multiple Meeting Option

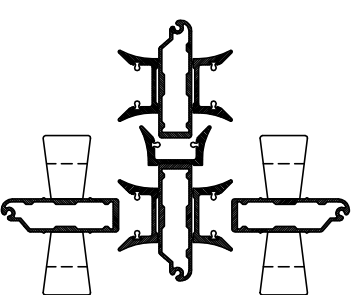

THESE SPECIFICATIONS ARE SUBJECT TO CHANGE WITHOUT NOTICE

Stack Dimensions

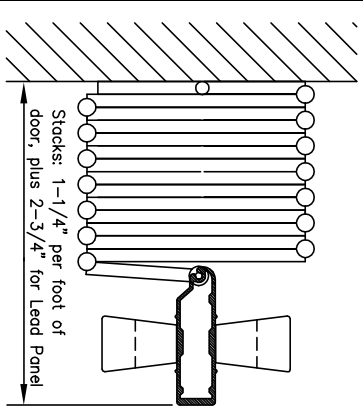

Intermediate Rolling Post

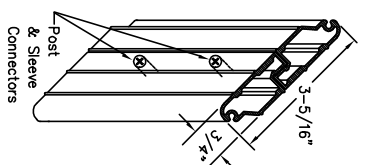

Privacy Latch

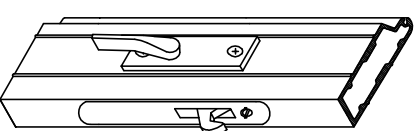

Keylock

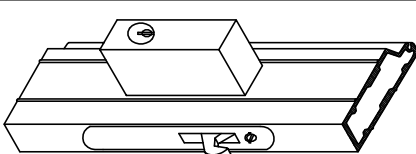

Single Cremone Bolt Keylock

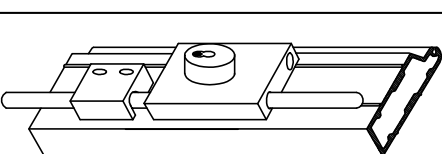

Double Cremone Bolt Keylock

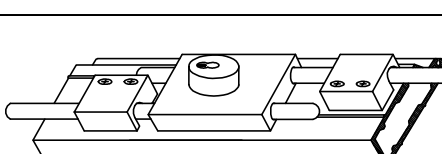

INFORMATION

Width: Custom made to any width
 Height: Custom made to 10' - 1"
 Panels: Aluminum: Solid or Perforated
 Side Channel: Aluminum: Clear
 Panel Connector: Flexible Vnyi: Clear
 Coordinated with side channel
 Steel: Clear
 Hinge System: Ball bearing nylon wheels on steel axes
 Wheels: Aluminum (straight or curvable); Clear
 Track: Aluminum (straight only); White
 Recessed Channel/ "Hat" Channel: Aluminum: Clear
 Lead, Intermediate and Jamb: Thumb Turn two sides
 Latch Header: Construction Details by Others
 Door Weight: Average Weight
 Height: 6'-8" 10lbs. Per lined foot
 8'-1" 12lbs. Per lined foot
 10'-1" 15lbs. Per lined foot

See Woodfold Accordion Door brochure for additional details

Catch/Lock Options

Magnet with strike plate
 Privacy Latch: Deadlatch with thumb turn one side
 Springlatch: Springlatch with thumb turn two sides
 Keylock 1 Side: Deadlatch with thumb turn one side, keylock one side
 Key and Single Bolt: Key and single bolt lock
 Key and Double Bolt: Key and double bolt lock
 Single Cremone: Single Cremone Bolt with Key Lock
 Double Cremone: Double Cremone Bolt with Lock
 Footbolts: Locking or non locking
 Other Keyed Options: Keyed alike, custom keyed, construction core
 Contact manufacturer for more details

Job Name: _____
 Job Location: _____
 Supplier: _____
 Architects Acceptance

Qty.	Single/Pair	Single End/Double End	Left or Right Stack	Width X Height	Finish/Color	Comments

THESE SPECIFICATIONS ARE SUBJECT TO CHANGE WITHOUT NOTICE

Woodfold—Marco Mfg. Inc.
 P.O. Box 346 Forest Grove, OR. 97116
 http://www.woodfold.com

Phone: 503-357-7181
 Fax: 503-357-7185
 640 SD 6/03